

uScore Netball

Portable Netball Post Water Base Assembly instructions

CONTENTS:

1. Ring (1PC)
2. Net (1PC)
3. Top pole cap (1PC)
4. Lower pole (1PC)
5. Middle pole (1PC)
6. Middle pole (1PC)
7. Top pole (1PC)
8. Molded base (1PC)
9. Axle (1PC)
10. Wheel (2PCS)
11. Lower left brace (1PC)
12. Lower right brace (1PC)
13. Molded base cap (1PC)
14. M8 screw & nut set (4PCS)
15. M8 x 16 screw & nut set (4PCS)
16. M8 x 53 screw & nut set (1PC)
17. M8 x 59 screw & nut set (1PC)
18. Screw (4PCS)
19. Tool set (3PCS)

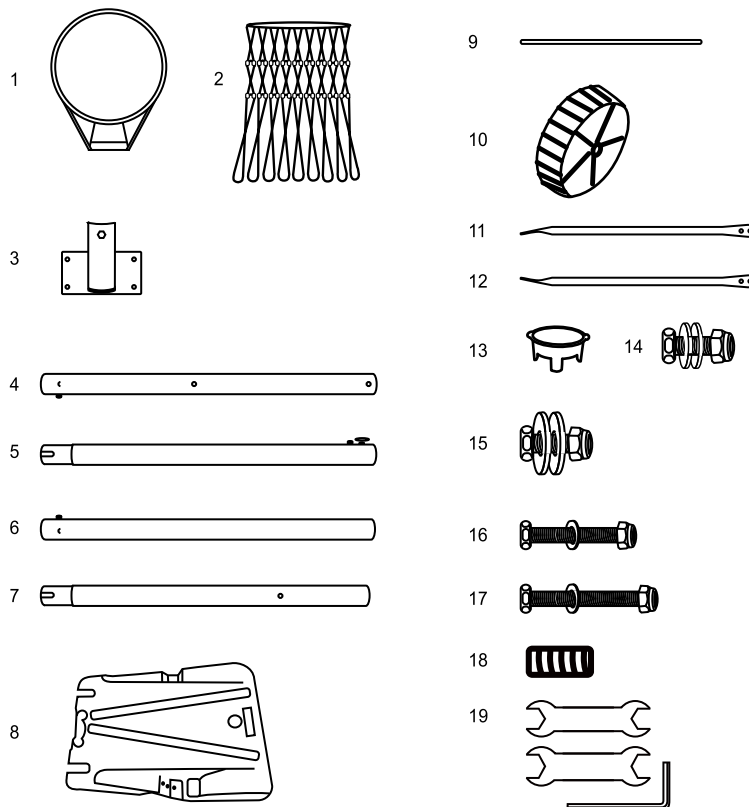

ASSEMBLING THE NETBALL STAND SET

Check all contents are included before assembly.

CAUTION

1. Always assemble and disassemble the netball stand set under adult supervision.
2. Any breakage found on the tube, please stop assembling or disassembling it.
3. Do not hand or climb on the product.

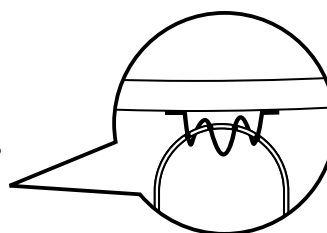
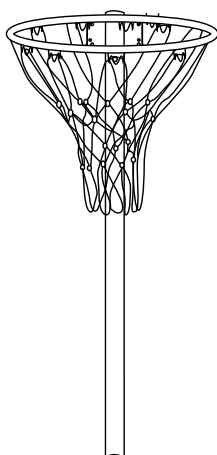
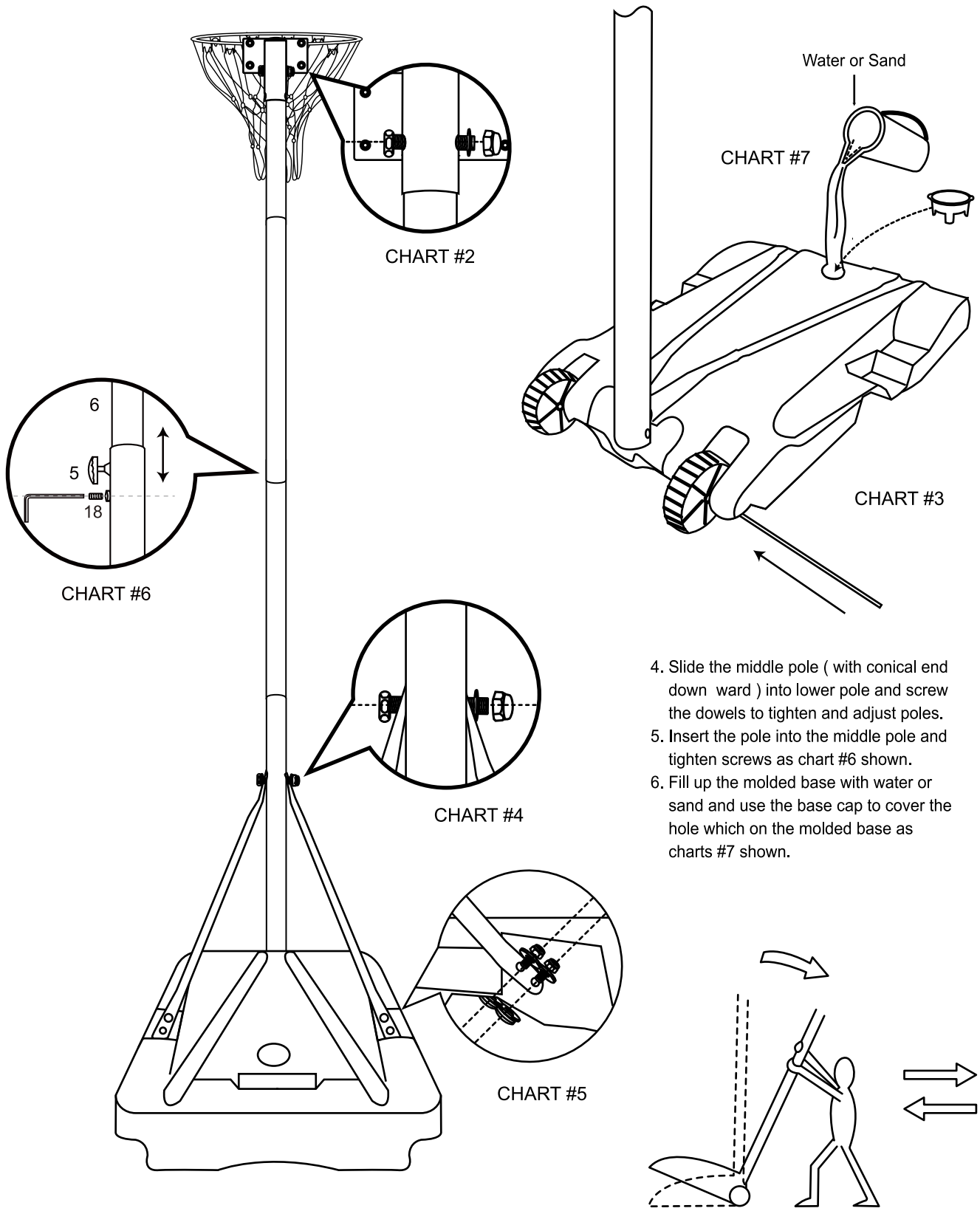

CHART #1

1. Hanging the net on the metallic hooks around the ring; affix the net as chart #1 shown.

2. Insert the top pole (with the end of two holes upward) into the top pole cap and fasten them with screw (#16) as chart #2 shown.
3. Assemble wheels and lower pole (conical end upward) on the moulded base with axle across them as chart #3 shown. Assemble and fasten lower right and left braces on lower pole with screw (#15) and on molded base with screw (#17) as chart #4, #5 shown.



4. Slide the middle pole (with conical end downward) into lower pole and screw the dowels to tighten and adjust poles.
5. Insert the pole into the middle pole and tighten screws as chart #6 shown.
6. Fill up the molded base with water or sand and use the base cap to cover the hole which on the molded base as charts #7 shown.

